

Serrature supplementari a cilindro
Additional locks cylinder movement

S.A.B.

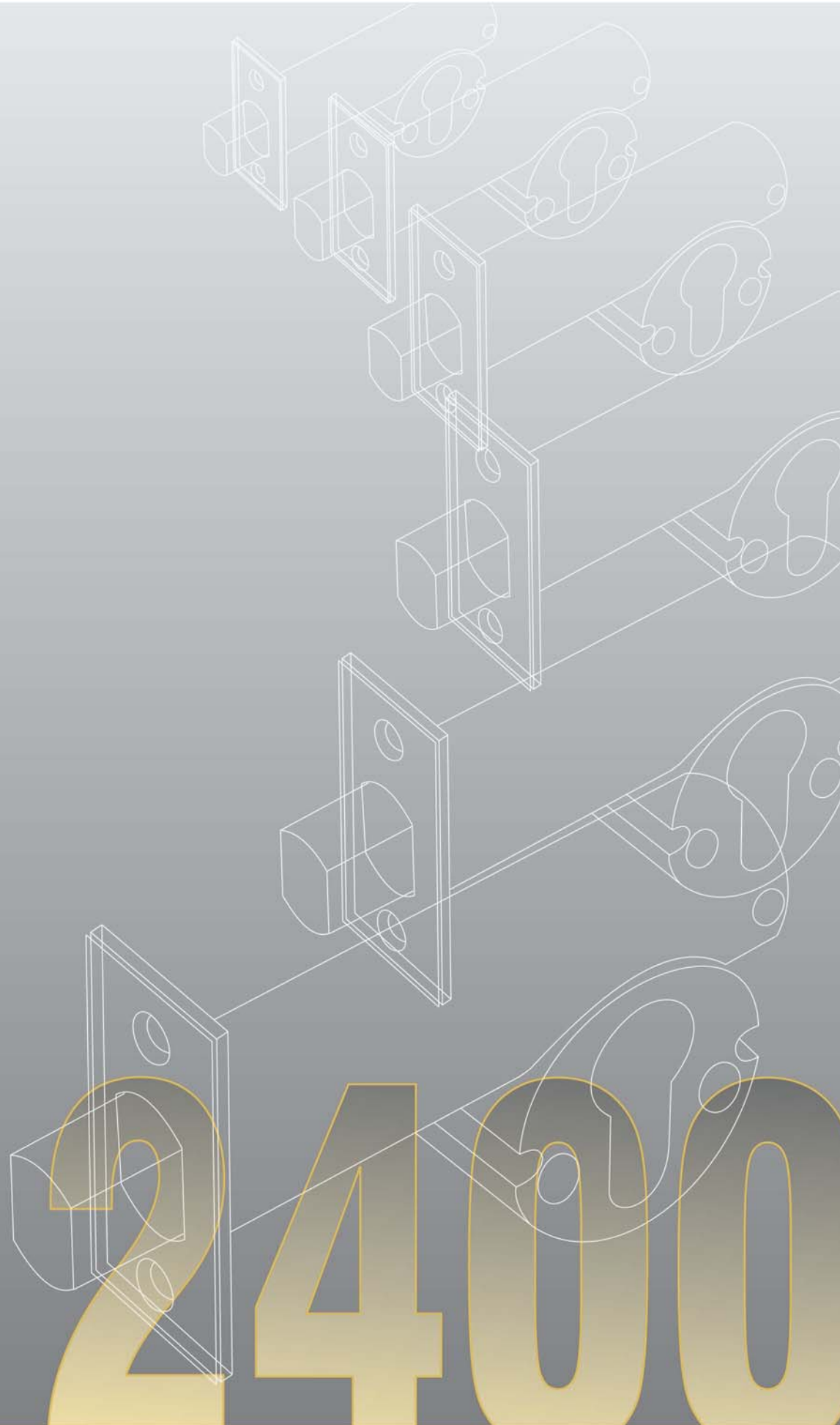

2400

Serratura supplementare a cilindro
1 Mandata
Uscita catenaccio 16mm
Azionamento a cilindro

Additional lock cylinder movement
1 Turn
Bolt projection 16mm
Cylinder movement

FINITURA DI SERIE

- Catenaccio, Piastra frontale, Contropiastra OLV

STANDARD FINISHINGS

- Bolt, Front plate, Striking plate OLV

DOTAZIONE

- Viti di fissaggio
- CILINDRO ESCLUSO

ACCESSORIES

- Fixing screws
- CYLINDER NOT INCLUDED

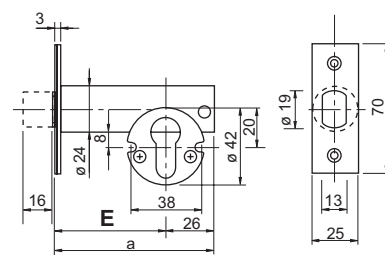

Codice Code	Finitura Finishing				
02400 51	---	1	25x3x70	51	1
02400 60	---	1	25x3x70	60	1
02400 70	---	1	25x3x70	70	1

Entrata Backset	OLV	OCL	OCS	ONS	PLO	OS	OB	OGR	AB	OBL	SFE	OBS	€
51, 60													
70													

2400

2450

Coppia bocchette DIA 52mm - Foro cilindro Interasse viti 38mm	Pair escutcheons DIA 52mm - Cylinder Hole Screw distance 38mm
FINITURA DI SERIE • Finitura standard OLV	STANDARD FINISHINGS • Standard finishing OLV
DOTAZIONE • Viti di montaggio • Distanziali	ACCESSORIES • Assembly screws • Spacers

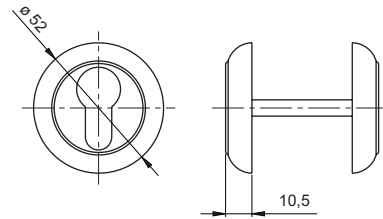

2400

Codice Code	Finitura Finishing		OLV	OCL	OCS	ONS	PLO	OS	OB	OGR	AB	OBL	SFE	OBS	€
02450	---	10													

240017

Maschera di foratura
ISTRUZIONI PER L'UTILIZZO DELLA MASCHERA DI FORATURA

La maschera di foratura consente di realizzare l'intera sede della serratura supplementare a cilindro Art. 2400 con l'aiusilio degli specifici utensili. Dispone di una guida frontale per la punta $\varnothing 25$, che realizza la sede del corpo serratura e 9 posizioni laterali relative alle varie entrate 51, 60, 70, per il preforo $\varnothing 6,3$ da poter utilizzare sia sul lato destro che su quello sinistro della porta. La serie centrale di fori invece serve per l'eventuale lavorazione della sede dello scrocco maniglia. Sulla parte frontale la maschera è dotata di una regolazione per l'esecuzione dell'alloggiamento nella posizione desiderata.

*Drill Jig
INSTRUCTIONS FOR DRILL JIG USE
The supplied drill, jig and tools, allow to make the complete installation of cylinder lock, our Art.2400.
A frontal mask for $\varnothing 25$ drill bit, makes the lock housing. It offers 9 positions for the different entrances 51, 60 and 70 for $\varnothing 6,3$ hole, to be used both on right and left side of door.
The central set of holes works for eventual lead hole for handle core. The frontal side of, jig can be regulated according to the required size for lock housing.*



FINITURA DI SERIE

-

STANDARD FINISHINGS

-

DOTAZIONE

-

ACCESSORIES

-

Codice

Code

240017

€



1

€

240018

Fresa speciale per legno DIA 25mm

Special drill mill for wood DIA 25mm

FINITURA DI SERIE

-

STANDARD FINISHINGS

-

DOTAZIONE

-

ACCESSORIES

-



Codice

Code

240018

€



1

€

2400

240019

Punta ad elica DIA 6,3mm	Drill bit DIA 6,3mm
FINITURA DI SERIE	STANDARD FINISHINGS
•	•
DOTAZIONE	ACCESSORIES
•	•



Codice	€	➡	€
Code			
240019		1	

240020

Fresa a tazza DIA 1" 3/4 - (44mm)	Drill mill DIA 1" 3/4 - (44mm)
FINITURA DI SERIE	STANDARD FINISHINGS
•	•
DOTAZIONE	ACCESSORIES
•	•







Codice	€	➡	€
Code			
240020		1	

2400

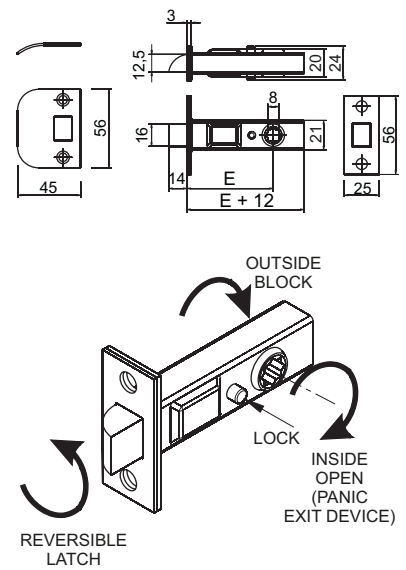
2500

<p>Versione Privacy Funzione antipanico sblocco Latch maniglia Solo lato interno Quadro 8 mm indipendente Lato interno e lato esterno Apertura Latch con rotazione di 15° del quadro 8 mm</p>	<p>Privacy version <i>Panic exit device function</i> <i>Unlock the latch with handle</i> <i>Internal side only</i> <i>Double square hole 8 mm</i> <i>Internal side and external independent</i> <i>Open the latch with only 15°</i> <i>rotation of the handle</i></p>
<p>FINITURA DI SERIE</p> <ul style="list-style-type: none"> • Finitura standard OLV 	<p>STANDARD FINISHINGS</p> <ul style="list-style-type: none"> • Standard finishing OLV
<p>DOTAZIONE</p> <ul style="list-style-type: none"> • Piastra e contropiastra • Viti di fissaggio 	<p>ACCESSORIES</p> <ul style="list-style-type: none"> • Front plate and Striking plate • Fixing screws



Codice Code	Finitura Finishing			
02500 60	---	25x3x56	60 (2" 3/8)	1
02500 70	---	25x3x56	70 (2" 3/4)	1



Entrata Backset	OLV	OCL	OCS	ONS	PLO	OS	OB	OGR	AB	OBL	SFE	OBS	€
60 (2" 3/8)													
70 (2" 3/4)													

2550

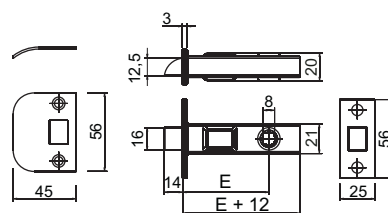
<p>Versione Passage Quadro 8 mm Apertura Latch con rotazione di 15° del quadro 8 mm Serratura simmetrica e orientabile per porte DX e SX</p>	<p>Passage version Square hole 8 mm Open the latch with only 15° rotation of the handle Completely orientable for right or left doors</p>
<p>FINITURA DI SERIE</p> <ul style="list-style-type: none"> Finitura standard OLV 	<p>STANDARD FINISHINGS</p> <ul style="list-style-type: none"> Standard finishing OLV
<p>DOTAZIONE</p> <ul style="list-style-type: none"> Piastra e contropiastra Viti di fissaggio 	<p>ACCESSORIES</p> <ul style="list-style-type: none"> Front plate and Striking plate Fixing screws



2550

Codice Code	Finitura Finishing			
02550 60	---	25x3x56	60 (2" 3/8)	1
02550 70	---	25x3x56	70 (2" 3/4)	1

Entrata Backset	OLV	OCL	OCS	ONS	PLO	OS	OB	OGR	AB	OBL	SFE	OBS	€
60 (2" 3/8)													
70 (2" 3/4)													

